

XP400

HAMILTON DESIGN

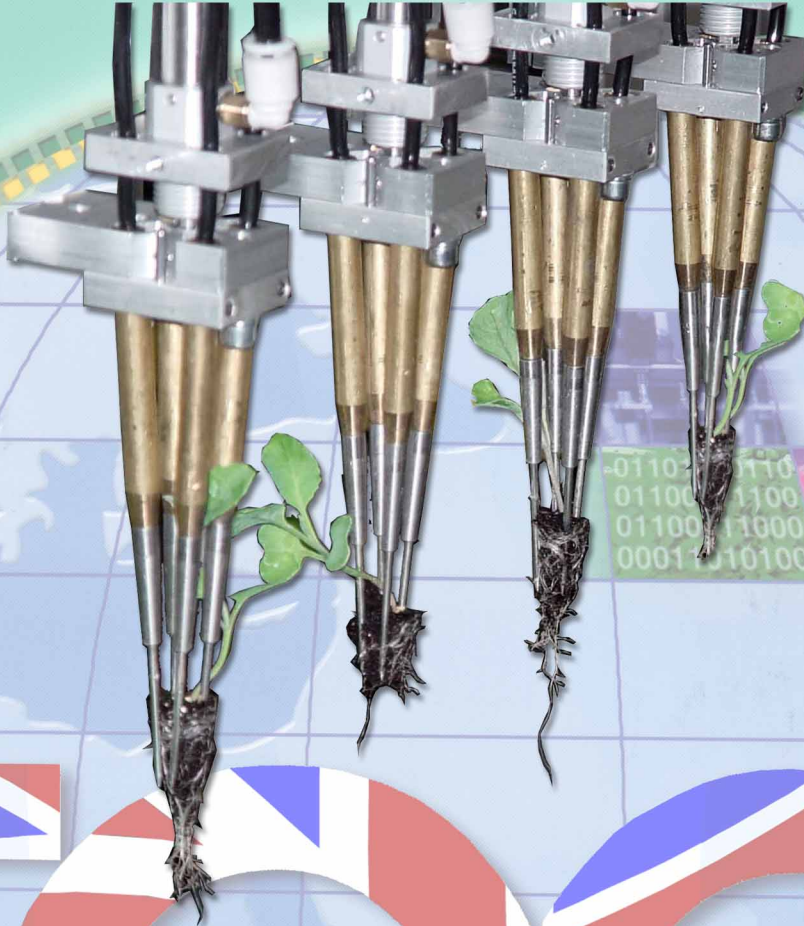

TRIO

P R O J E C T

XP 404N Transplanter

**READ ALL THE INFORMATION IN THIS MANUAL BEFORE
USING THE MACHINE.
FOLLOW THE INSTRUCTIONS CAREFULLY.
KEEP CHILDREN UNDER SUPERVISION WHILE THE MACHINE
IS OPERATING.**

The XP trasplanter will transplant young plants from the plug trays in which they are grown into larger plug trays, packs or strip trays.

1	TECHNICAL DATA	PAGE	02
2	TRANSIT	PAGE	02
3	INSTALLATION	PAGE	03
4	SAFETY NOTES AND PRECAUTIONS	PAGE	04
5	MAIN COMPONENTS	PAGE	05
6	CONTROL BUTTONS	PAGE	07
7	PRELIMINARY CHECKS AND STARTUP PROCEDURES	PAGE	09
8	PROGRAMMES	PAGE	10
9	OPERATION	PAGE	12
10	PROGRAMMING DURING OPERATION	PAGE	15
11	EXAMPLE OF A WORKING CYCLE	PAGE	17
12	SETUP AND ADJUSTMENT OF TRANSPLANTING HEADS	PAGE	18
13	DESCRIPTION OF AXES	PAGE	19
14	PROGRAMMING GUIDE	PAGE	22
15	MAINTENANCE	PAGE	33
16	XP 404N	PAGE	35
17	ECO-FRIENDLY DISPOSAL OF OBSOLETE PARTS	PAGE	35



via Zaffi 33/c
42100 Reggio E.
ITALIA
tel. +39 0522
333617
fax +39 0522
393768

info@teaproject.it
www.teaproject.it

CHAPTER 1: TECHNICAL DATA

HEIGHT	1.795 mm
WIDTH	1.500 mm
LENGTH	2.330 mm + 590 mm
WEIGHT	KG. 400
VOLTAGE	240V -110V
POWER	16 A
AIR PRESSURE	6 BAR
NOISE LEVEL	less than 70 DECIBEL

CHAPTER 2: TRANSIT

- During transit the transplanter must be fixed onto a level surface to avoid vibration damage.
- Secure the X Axis trolley by tying to the left or right end of the machine.
- Place a piece of polystyrene or sponge under the Y trolley to avoid contact with the machine surface.
- Check carefully at the time of delivery that the machine is undamaged.
- To move the transplanter on level surfaces lift up the four anti-vibration feet and use the four swivel wheels
- Great care must be taken when loading and unloading with a fork-lift truck. The machine **MUST** be kept level, and all four feet must touch the ground simultaneously. Use the two fork lift straps provided



tea
PROJECT

via Zatti 33/c
42100 Reggio E.
ITALIA
tel. +39 0522
333617
fax +39 0522
393768

info@teaproject.it
www.teaproject.it

CHAPTER 3: INSTALLATION

Before starting the machine check the following:

Location of the machine

The machine must be placed indoors in a safe and sheltered place, on a level surface. It is essential that the four anti-vibration feet are completely level on the floor. Check that the machine surface is perfectly horizontal. The floor should be as clean as possible from grease, dust and soil.

Electrical supply

The machine requires an electrical supply of 220V-1Kw. The connection requires an outlet of 240V - 16A+ground. The electrical system must be installed and protected in accordance with current standards.

Countries with electrical supply of 110 volts

The machine requires an electrical supply of 110V-1Kw. The connection requires an outlet of 110V - 16A+ground. The electrical system must be installed and protected in accordance with current standards.

Pneumatic supply

The machine requires a compressed air supply to be connected to the 8mm push-in fitting on the air filter located on the right hand side of the machine.

The inlet is fitted with an anticondensation filter and an air-line lubricator. Levels should be checked periodically. Push the button situated below the filter to empty it. The minimum pressure required is 6 bars. To adjust the required pressure, operate on the knob placed over the pressure gauge



tea
PROJECT

via Zaffi 33/c
42100 Reggio E.
ITALIA
tel. +39 0522
333617
fax +39 0522
393768

info@teaproject.it
www.teaproject.it

CHAPTER 4: SAFETY NOTES AND PRECAUTIONS

4.1 GENERAL SAFETY

- Read all instructions carefully before use.
- Install and set up the machine as directed in this manual.
- Do not remove the safety guards from moving parts.
- Ensure the safety guards are in place before starting the machine.
- Be careful not to catch any loose clothing in moving parts.
- Electrical servicing should only be undertaken by specialist electricians or the supplier.

Before switching on the machine ensure that the side panels, plastic safety guards and the doors are all closed and secure.

The company cannot be responsible for the occurrence of any fault or accident if these safety precautions are not followed or the safety guards are insecure or have been tampered with.

Carefully read chapter 10 which describes the operation of the machine and only operate as instructed.

Make sure that the earth conductor is connected.

Make sure that there are no objects which can obstruct, damage or stop the movements of the heads

Make sure that there are no animals, children, or uninstructed personnel near the machine when starting up.

4.2 OPERATOR SAFETY

It is vital that the machine operators fully understand the transplanter's components, setup, operation and programming procedures before use, to avoid inappropriate and dangerous operation of the machine.

Under no circumstances should an operator attempt to alter or adjust any of the operating components while the machine is working.

The machine is fitted with openable safety guards to protect the operator from the moving parts, and are fitted with a security switch. If these guards are opened during operation the machine will stop, as if an emergency button has been pressed.

If the removal of the safety guards is necessary, only do so after disconnecting the system from any type of energy source, and ensuring the machine is earthed, and fitted with a circuit breaker appropriate for the type of electrical supply.

Ensure correct electrical connection and connection to



ground, in order to avoid electrostatic charges which could be both dangerous for the operator and cause of sparks, with associated fire danger in the presence of inflammable material.

CHAPTER 5: MAIN COMPONENTS

5.1 Controlled Axes

The XP400 controls 5 axes electronically: X axis, Y axis, U axis, Z axis and W axis.

Viewed from the front of the machine, the 5 axes are as follows:

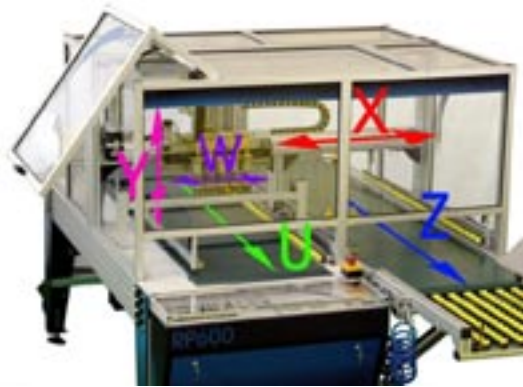

X Axis: Fingers move horizontally from right to left, and back, powered by 48V direct current motors. .

Y Axis: This is the vertical movement of the fingers picking up the seedlings from the plug tray and placing them in another tray or pack. Movement is powered by a 48V direct current motor. Fingers move up ward and down ward

U Axis: The U Axis is the track situated on the left of the machine. This transports the plug trays containing the seedlings ready for transplanting the conveyor belt is connected to a 48V electric motor, located at the front of the machine. The track moves forwards towards the operator.

Z Axis: The Z Axis is the track situated on the right of the machine. A conveyor belt transports the empty trays or packs into which the seedlings will be transplanted. The conveyor belt is powered by a 48V electric motor, located at the front of the machine, usually on the right-hand side. The conveyor moves forwards towards the operator.

W Axis: The W Axis sets the finger spacing according to the cell configuration of the pickup and placement trays and packs. Movement is powered by a 48V direct current motor.

5.2 Computer

The computer is situated on the control cabinet on the left side of the machine. It contains all the controls for programming and operating the machine. Avoid getting water on the control panel, and protect it from blunt instruments and naked flames. Clean with a soft damp cloth, do not use detergents or chemical products. Opening the computer should not be necessary, and should not be undertaken by the operator; should necessity arise, contact the suppliers.



5.3 Emergency buttons

Red emergency buttons are located on the black panels at the right and the left of the transplanter and on the additional emergency keyboard (see chapter 6.2) at the front of the transplanter. The machine can be stopped at any time by pushing one of these buttons. Once pushed, the emergency button is illuminated, as is a warning light on the front panel, and a warning message is displayed on the screen. The machine remains inoperable until the emergency button is pulled back out and the green Auxiliary On/Reset button is pressed.





5.4 Clear plastic main safety guard

The clear plastic safety guard of the machine can be opened by lifting it upwards.

If opened during use operation will stop automatically. The guard must be closed and the Auxiliary on/Reset button pressed before operation can continue. The safety guards and security switches must not be tampered with.



5.5 Control Cabinet

The control cabinet houses the electrical board and it is located at the back of the clear plastic safety guard. Do not attempt to make alterations or adjustments inside the control cabinet, unless specifically instructed to do so by your authorised TEA dealer.



5.6 U Axis micro switch

The U Axis micro switch is located between the central U and Z Axis guides. It senses when a tray is approaching the pickup position. To clear trays from this area, see the procedure in the following chapters; do not manually remove trays as this risks damage to the micro switch.

5.7 Z Axis micro switch or photocell

The Z Axis micro switch (a photocell in some models) is located next to the U Axis micro switch. It senses when a tray is approaching the placement position. To clear trays from this area, see the procedure in the following chapters; do not manually remove trays as this risks damage to the micro switch.

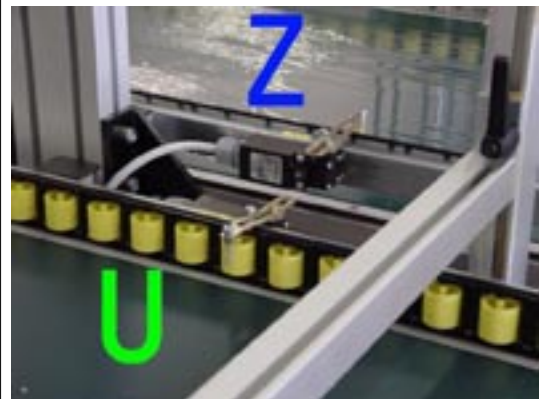

CHAPTER 6: CONTROL BUTTONS

Control buttons, manual switches, and lights marked with a yellow label are placed on the control panel on the left side of the machine together with the EM11 computer.

Below follows a description of the control buttons and manual knobs.

In the following chapters the full use of each control button will be described in details.



6.1 Buttons, lights and switches

Red power switch

The red power switch switches the machine on and off.

MANUAL Switch

AXIS "U" button

AXIS "Z" button

Turning and holding the manual switch and pressing one of the two buttons "U" or "Z" axis will make these axes move.

This operation is quite

useful to move trays from the working area or to position them while a new programme is being made.

SIDE PICKUP / NEEDLES EXTEND switch



Turning this switch clockwise will make the pickup heads approach the plant's side during pickup.

This control is particularly useful for plants with big leaves.

Turning this switch anticlockwise the needles can be extended.

This control is useful for servicing and machine programming.

"LIGHT ON" switch

The light on switch switches on the internal lights of the machine.

Green "AUXILIARY ON / RESET" button

The green auxiliary on button has to be pressed every time the machine is switched on and every time an emergency button is pulled back out.

Red "EMERGENCY" light

This is a warning button, which lights when the machine stops due to emergency.

The light turns off after the green "AUXILIARY ON" button is pressed.



"POWER ON" light

This button lights to signal presence of power.

6.2 Additional KEYBOARD

An additional keyboard is located nearby the exit of the trays into which seedlings have been planted.

It contains the following control buttons:



Red STOP button

Green START button

These two buttons, situated on the right side of the keyboard start and pause the machine's working cycle.

Green "AUXILIARY ON (RESET)" button

Red "EMERGENCY" button

6.3 EM11 computer keyboard

Alphanumeric keyboard

To enter machine data

Red STOP key

Green START key

By pressing the green "Start" button the machine starts its working cycle, by pressing the red "Stop" button the cycle is paused (if pressed once) or the program is stopped (if pressed twice).

This red stop key differs from the red stop button previously described, as by pressing it once the cycle is temporarily suspended (cycle paused) but by pressing the red button the programme is terminated.

MEM key

Used as access key in combination with "DOUBLE ARROW" button to enter the protected area of the computer (programming mode and configuration) and to store data when programming.

MENU key

To access the main menu

DOUBLE ARROW key

Normally advances the cursor along each step of the program line.

ARROW key (up down right left)

To move manually the X and Y axes, to increase or decrease the working speed, to change the depth value etc.

P1, P2 and F1 buttons will be described later

"C" key

Clears the entry above the current cursor position.

END/HOME key

Resets the machine when switched on, used also for programming.

6.4 EM11 computer display

The computer display shows useful messages when using and programming the machine.

6.5 Serial Port

The RS 232 located at the back of the computer inside the control cabinet, allows the connection of the EM11 computer to a PC for data exchange



Computer EM11



tea
PROJECT

via Zatti 33/c
42100 Reggio E.
ITALIA
tel. +39 0522
333617
fax +39 0522
393768

info@teaproject.it
www.teaproject.it

CHAPTER 7: PRELIMINARY CHECKS AND STARTUP PROCEDURE

7.1 Before switching on

Before switching on the machine check the following:

- Air pressure should be at 6 bars
- The working area is cleared ready for use.
- The safety guards are correctly secured.
- The emergency buttons are not illuminated. If they are, reset. .

7.2 Starting the Transplanter

Connect the transplanter to the electricity and compressed air supplies.

Turn the red power switch (located on the right side of the control panel) one quarter turn clockwise.

The white 'Power On' and the red 'Emergency' lights will be illuminated.

Push the green AUXILIARY ON/RESET button, and then press END/HOME on the computer keyboard. This procedure will reset the transplanting heads to their datum position.



7.3 Starting a transplanting cycle



Press reset then
"END"



After pushing the "Auxiliary on" button, on the computer display the following message will appear:

LOW PRESSURE!

If the air pressure is insufficient, the message "Attention low air pressure" will be displayed and it will not be possible to continue until the pressure reaches the required level.

Before proceeding, remove any trays which may be under the working area of the transplanting heads, as follows:

- turn the black Manual knob clockwise and at the same time push the Z Axis or U Axis button
- the trays will be advanced back to the operator

Load the trays and packs onto the guides. The machine will advance the trays to the correct position in order to start the transplanting cycle.

7.4 Manual tray advancement

For manually moving trays in-between the two guide bars, proceed as follows:



Check that the green Auxiliary On/Reset light is on, and then turn the black Manual knob clockwise and at the same time briefly press either of the two buttons, Z Axis or U Axis.

Always remove the trays to avoid damage to the operator or to the machinery.

CHAPTER 8: PROGRAMMES

8.1 Definition of "Programme"

A programme is a sequence of instructions, to direct the transplanter to pickup seedlings from a specified plugtray and deposit them into another specified tray.

These instructions are referred to as PICKUP PROGRAMMES and PLACEMENT PROGRAMMES.

The XP400 allows for thirty PICKUP and thirty PLACEMENT programmes, which can be used in any combination, i.e. it is possible to transplant seedlings from any one of 30 different tray types into any one of 30 different destination trays.

A transplanting operation simultaneously carries out one PICKUP and one PLACEMENT programme. The PICKUP programme instructions are carried out on the left of the machine, where seedlings are picked up in the transplanting fingers, and then the PLACEMENT programme instructions are executed on the right where the plants are deposited into their destination trays.

8.2 Stored programmes

Up to thirty PICKUP programmes and thirty PLACEMENT programmes can be written directly with the EM 14 control keypad; once written, they are stored in the memory and allocated an individual number. It is possible to delete and/or replace programmes at any time.

The required programmes are chosen via the display, as illustrated.

After pushing the END/HOME button this message will

```
P: __ PICKUP
P: __ PLANTING
```

appear automatically, alternatively it can be accessed by the main menu by choosing the option "<1> AUTOMATIC".

```
<1>AUTO <2>MAN.
<3>DATA <4>TEST
```

Full instructions for writing, amending, storing and choosing programmes can be found towards the end of this manual.

Always keep a written copy of all programmes on the blank sheets provided, in case of memory failure.

The display and programmes

When the machine is switched on the following message will be displayed:

```
Press reset then
"END"
```

Programm screen: Before starting a working cycle, the following message will appear:

PICKUP programme: Pickup programme number

```
P: __ PICKUP
P: __ PLANTING
```

PLACEMENT programme: Placement programme number

Automatic Menu:

```
P: __ PICKUP
SPEED 10%
```

Working speed (percentage)

During a working cycle, the following message will appear:

```
P: __ PICKUP
PLANTING :139.5
```

Planting depth

```
PICKUP : 000
PLANTING: 000
```

Number of worked trays both in pickup and placement

The display and programmes

MAIN MENU

When the <MENU> button is pushed, the following message appears:

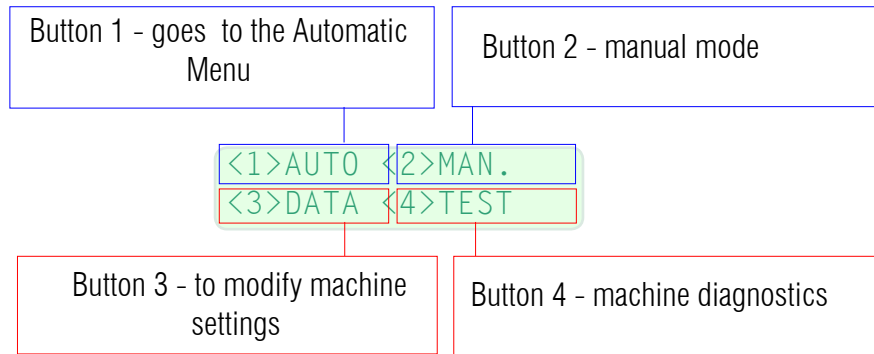

Button number <3> and <4> are only to be used by trained personnel

When <STOP> button is pressed, the working cycle is suspended and the following message appears:

P:28 PICKUP
CYCLE PAUSED

When the <emergency> button is pressed, or the front safety guard opened, the working cycle is suspended, and the following message appears:

P:28 PICKUP
EMERGENCY

Emergency and consequent stop of the machine due to a non-count of the encoder of the displayed axis.

encoder
ERROR #

CHAPTER 9: OPERATION

9.1 Running a stored programme

Press the "Auxiliary on/Reset" button then the END/HOME key. This prompts Axes Y, W, and X to reset.

Press reset then "END"



The following message will be displayed:

P: 1 PICKUP
P: 1 PLANTING

To select the required Pickup and Placement programmes: press P1, and use the ↔ to move the cursor under the PU and PL (Pickup and Placement) numbers. Use the number pad to key in the appropriate programme numbers.



P: 1 PICKUP
P: 1 PLANTING



P: 5 PICKUP
P: 1 PLANTING



P: 5 PICKUP
P: 1 PLANTING



P: 5 PICKUP
P: 8 PLANTING

Attention: Before proceeding, remove any trays which may be under the working area of the transplanting heads, as follows:

Turn the black Manual knob clockwise and at the same time push the Z Axis or U Axis button. The trays will be advanced back to the operator

Press "START". The machine will start its working cycle and the following message will appear:



P: 5 PICKUP
SPEED 50%

The U Axis and Z Axis guides bring the first tray into position as the transplanting heads move into their pickup position, and the working cycle begins.

Start at a low speed(5% - 10%) to check the transplanter is running correctly, and then alter the speed to suit



P: 5 PICKUP
SPEED 10%

by pressing the up or down arrows. Pressing either of these will temporarily stop the machine and display the speed.

9.2 To stop the machine

Press "STOP". The working cycle will be suspended and the following message will be displayed.

There are now two possibilities: to continue with the cycle, or to quit the programme and return to the start position.



P: 5 PICKUP
CYCLE PAUSED

To restart, press "START"

To quit the programme, press "STOP"

9.3 Stopping and restarting the machine



If the machine has been stopped and this message is displayed, proceed as follows:
-Push the **START** button.
The machine will continue from the point in which it was stopped.

P: 5 PICKUP
CYCLE PAUSED

NB: It is important to ensure that no trays are moved while the cycle is paused.



-Push the **STOP** button
The paused programme will be cancelled and the transplanter will return to the start position. Having selected an appropriate programme, push **START** to restart the machine.



P: 5 PICKUP
P: 8 PLANTING

NB: Before restarting the machine clear any trays from the working area.

It is safe to pause and restart (or reset) the programme at any time providing these instructions are followed. Never attempt to touch any of the moving parts without first stopping the cycle.

9.4 Stopping the machine using the Emergency Stop buttons

Pushing one of the red and yellow emergency buttons will bring the machine to an immediate stop, as will opening the front safety guard.

The following message will be displayed:

P: 5 PICKUP
EMERGENCY

The machine remains inoperable until the emergency button is pulled back out and the green "Auxiliary On/Reset" button is pressed, followed by the "START" button. The cycle will resume from where it was stopped.



9.5 If the transplanter stops due to low air pressure

If the pressure is too low, the machine will stop and the following message will be displayed:

LOW PRESSION

Check the compressor is operating correctly, and that the airlines are clear.
When the necessary air pressure is reached, the message will disappear.
The cycle can be resumed by pushing the "START" button.

9.6 Data parameters warning

If the programme contains data which exceeds the operating limits, the following message will be displayed:

DATA
ERROR

Modify the programme, keeping data within the parameters.

9.7 Drive gear emergency

If there is a fault with one of the motor control circuit boards, the following message will be displayed:

DRIVE GEAR
EMER.

Try to restart the machine, by turning off the main power switch and resetting the machine.

If the message recurs, contact your authorised TEA dealer.

9.8 Encoder count alarm

The message "encoder Error axis #/" is displayed when the encoder of one of the axes (X, Y, W) fails to count.

The problem is due to a fault of the displayed axis (encoder, motor, control...) or to an obstruction which has

unexpectedly stopped its movement.

encoder
ERROR AXIS #

9.9 Encoder Position

After switching on the machine, and as soon as the re-setting procedure is finished, the display will show the datum positions of the encoder disks, for 5 seconds. These are numeric values for the X, Y & W axis encoders, and are used for servicing or fault finding. The values can vary between 1 and 500. When correctly adjusted these readings should be between 200 and 300. If the values are close to 1 or 500 then adjustment may be required. Contact Hamilton Design or their Agent for further information should this occur.

250 250 250

9.10 Side Pickup

Turning this switch clockwise will make the pickup heads approach the plants from the side during pickup. The fingers will go down to the pickup position and then move into the plants horizontally. This feature is particularly useful for plants with large leaves, when removing the plants from the top may cause damage to the foliage. Additionally, the lateral pickup will help avoid extracting neighbouring plants when the leaves are intertwined. Approaching the plants from the side will separate the leaves from adjacent cells. The side pick up can be engaged and disengaged at any time while the machine is running, as required.



tea
PROJECT

via Zatti 33/c
42100 Reggio E.
ITALIA
tel. +39 0522
333617
fax +39 0522
393768

info@teaproject.it
www.teaproject.it

CHAPTER 10: PROGRAMMING DURING OPERATION

Three parameters can be modified without stopping the working cycle: the speed, the tray counter and the depth.

10.1 Speed

The display shows the speed at which the machine is working, in percentage terms (as a proportion of the maximum speed).

P: 5 PICKUP
SPEED 95%



The value can be changed pressing ↑ and ↓

10.2 Tray counter

This electronically counts the number of the trays which have been transplanted.

Press "C" key to zero the tray counter.

PICKUP : 019
PLANTING: 023



10.3 Depth

This is the distance the fingers descend into the placement tray, expressed in mm.

The higher the number, the deeper the plant will be planted.

The value can be changed pressing ↑ and ↓

P: 5 PICKUP
PLANTING: 139.5

10.4 Modifying the speed and planting depth

As already described, by pressing the START button the machine begins its working cycle, and the second line of the display shows the speed value at which the

P: 5 PICKUP
SPEED 95%

machine is running. The speed can be adjusted using the ↑ and ↓ arrow buttons.

P: 5 PICKUP
SPEED 95%



P: 5 PICKUP
SPEED 10%

Press "F1" to go to the next display line (Depth)

Note that the ↑ and ↓ arrow buttons can be used to change



the value which appears above the cursor position.

Press the ↑ and ↓ arrow buttons to modify the "Planting Depth".

P: 5 PICKUP
PLANTING: 139.5

P: 5 PICKUP
PLANTING: 127.5



tea
PROJECT

via Zaffi 33/c
42100 Reggio E.
ITALIA
tel. +39 0522
333617
fax +39 0522
393768

info@teaproject.it
www.teaproject.it

Press "F1" again to display the "Tray Counter", which shows the number of trays which have been transplanted

P: 5 PICKUP
PLANTING: 127.5



PICKUP : 019
PLANTING: 023

To clear the Tray counter press "C" button

PICKUP : 019
PLANTING: 023



PICKUP : 000
PLANTING: 023

To go to the next line press "Double Arrow" button

PICKUP : 000
PLANTING: 023



PICKUP : 000
PLANTING: 023

To clear the Tray counter press "C" button

PICKUP : 000
PLANTING: 023



PICKUP : 000
PLANTING: 000

Press "F1" again to return to the first line of the display

PICKUP : 000
PLANTING: 000



P: 5 PICKUP
SPEED 10%

This returns you to the speed setting. Pressing the F1 key will toggle through the program options which can be changed while the machine is operating.

P: 5 PICKUP
SPEED 10%



P: 5 PICKUP
SPEED 50%

CHAPTER 11: Example of a working cycle

Start the machine

Press reset then
"END"



P:01 PICKUP
P:01 PLANTING

Select PICKUP programme No. 5 and PLACEMENT programme No.7

P:01 PICKUP
P:01 PLANTING



P:01 PICKUP
P:01 PLANTING

P:05 PICKUP
P:01 PLANTING



P:05 PICKUP
P:01 PLANTING

P:05 PICKUP
P:01 PLANTING



P:05 PICKUP
P:01 PLANTING

P:05 PICKUP
P:07 PLANTING



P:05 PICKUP
P:07 PLANTING

WHILE THE MACHINE IS WORKING

Increase the working speed from 10% to 50%

P: 5 PICKUP
SPEED 10%



P: 5 PICKUP
SPEED 50%

Change to the next display

P: 5 PICKUP
SPEED 50%



P: 5 PICKUP
PLANTING:139.5

Increase the transplantation depth by 5 mm

P: 5 PICKUP
PLANTING:139.5



P: 5 PICKUP
PLANTING:144.5

Pause the machine by pushing the STOP button

P: 5 PICKUP
SPEED 50%



P: 5 PICKUP
CYCLE PAUSED

P: 5 PICKUP
CYCLE PAUSED



P: 5 PICKUP
SPEED 50%

Stop the machine by pushing the EMERGENCY button

P: 5 PICKUP
SPEED 50%



P: 5 PICKUP
EMERGENCY

FINISHING A WORKING CYCLE

P: 5 PICKUP
SPEED 50%



P: 5 PICKUP
CYCLE PAUSED

P: 5 PICKUP
CYCLE PAUSED



P:05 PICKUP
P:07 PLANTING

TO ACCESS THE MAIN MENU

P:05 PICKUP
P:07 PLANTING



<1>AUTO <2>MAN.
<3>DATA <4>TEST

CHAPTER 12: MULTIPLE FINGER with variable distance

The trolley comprises moving transplanting heads. The moving heads run on a guide bar, and their distance from the fixed head is adjustable for both pickup and placement.

12.1 Removing the heads

XP transplanting heads can be removed from the trolley assembly by carefully unscrewing the central socket-



head screw on the mounting plate, and disconnecting the air tubes where they plug into the tee pieces at the



top. Use the plugs provided in the spares kit to plug the tee pieces.

NB. Before removing transplanting heads, disconnect both the electricity and air supplies. Both the fixed head and moving ones can be removed.

12.2 Head spacing

A motor controls the distance between the fixed and the



mobile heads and is programmable to correspond with the cell spacing of both pickup and placement trays. These adjustments are made at the programming stage, and should not be attempted mechanically.

The minimum and the maximum head distance depends on the type of the trolley used, the XP model and the number of heads.

A schedule listing the standard head distances for each model is shown below.

The values are subject change with improvements made by the manufacturing company and applied on new models.

Modell

	min. mm	max. mm
404N standard	45	140
special heads	35	140

12.3 Distance of the heads from the machine's working surface

The distance of the heads from the machine's working surface is expressed in mm. (Axis Y)

The distance is taken from the datum, the carriage being in the fully up position.

Depending on the XP model the maximum Y axis value varies between 180mm and 200mm from the datum to the transplanter table.

CHAPTER 13: XP AXIS

ATTENTION PLEASE!! THE EXAMPLE IS BASED ON A THREE HEAD SETTING

SEQUENCE 'X' AXIS programming sequence, for moving the 'x' axis

Position of the trolley after pressing < END > button ('0' position)

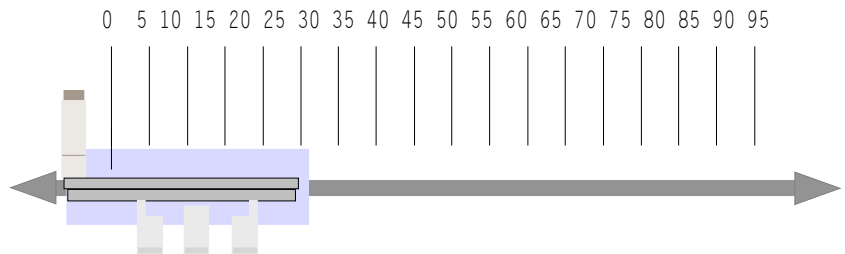

To move the trolley 500mm to the right enter: 'X + 500.0'. The trolley will stop 500mm from the zero position.

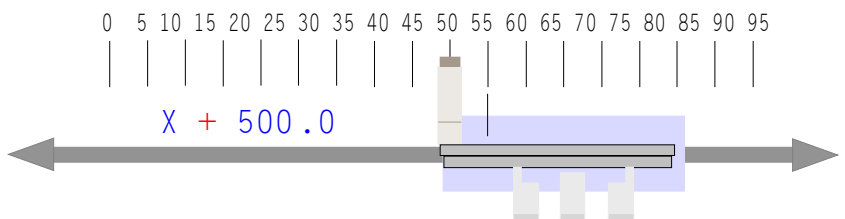

To move the trolley 350mm to the left enter: 'X - 350.0'. The trolley will stop 150mm from the '0' position.

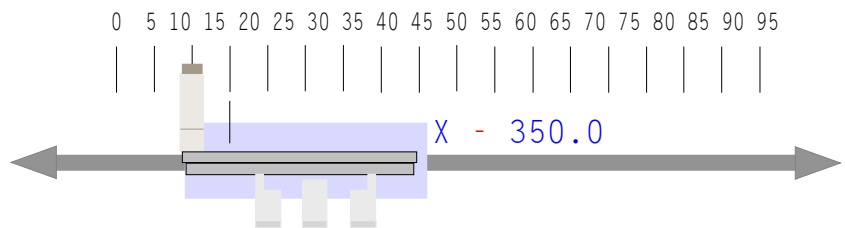

To move the trolley 150mm to the right enter: 'X + 150.0'. The trolley will stop 300mm from the '0' position.

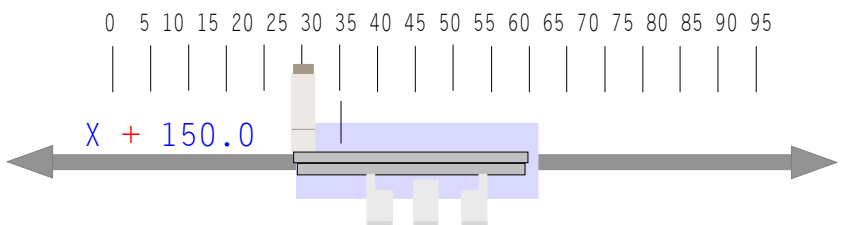

To move the trolley 300mm to the right enter: 'X + 300.0'. The trolley will stop at 600mm from the '0' position.

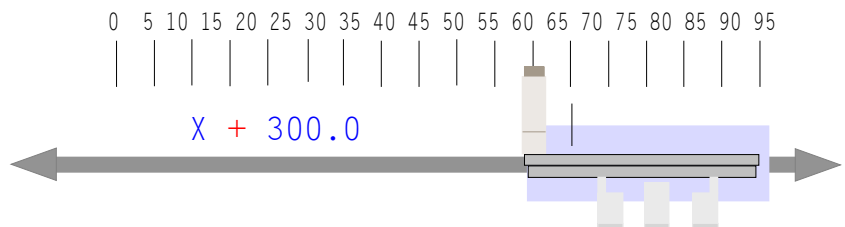

To move the trolley 600mm to the left enter: 'X - 600.0'. The trolley will stop at the '0' position.

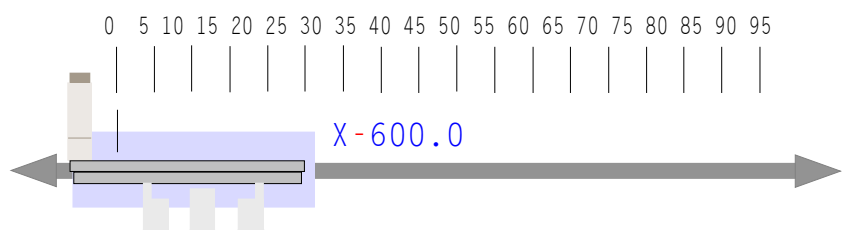

via Zaffi 33/c
42100 Reggio E.
ITALIA
tel.+39 0522
333617
fax+39 0522
393768

info@teaproject.it
www.teaproject.it

' Y ' AXIS controls sequence, for moving the 'y' axis

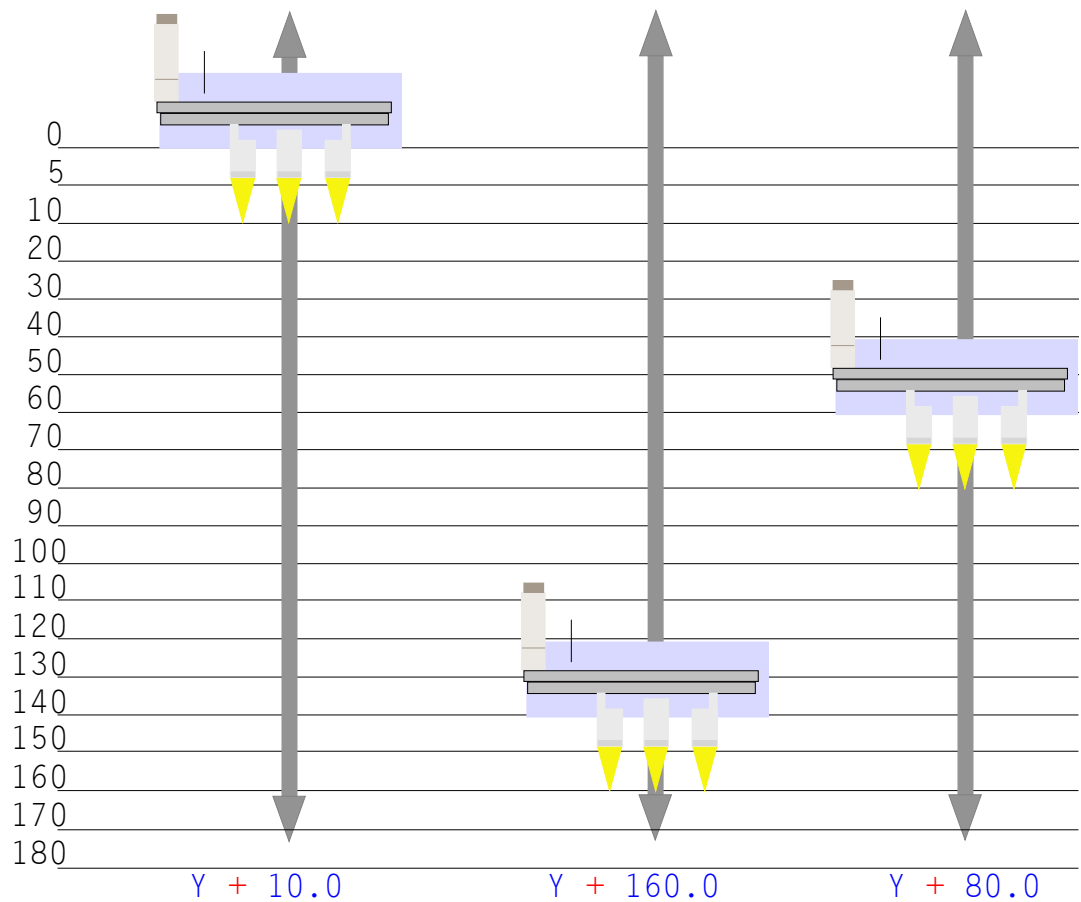
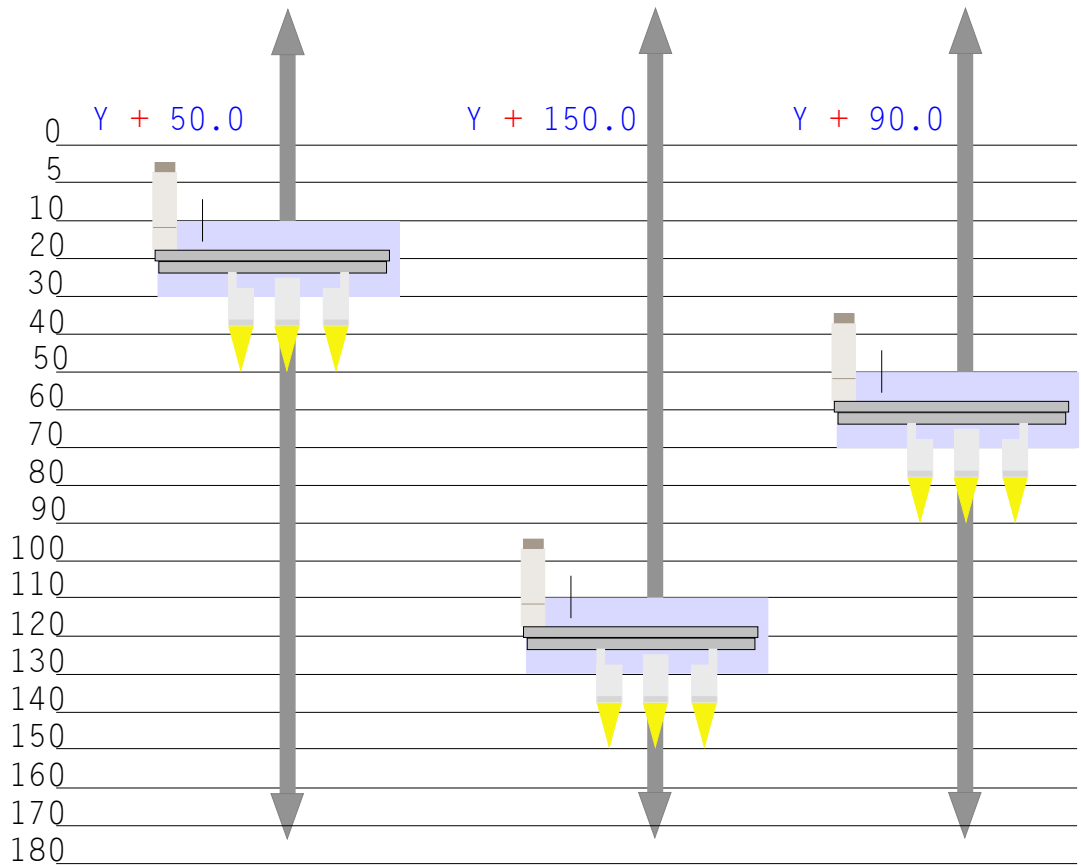

HAMILTON
 Green Lane
 Littlewick
 Green Berks
 SL6 3RH
 England
 Tel: +44 (0)
 1628 826747
 Fax: +44 (0)
 1628 822284

'W' AXIS controls sequence, for moving the 'w' axis

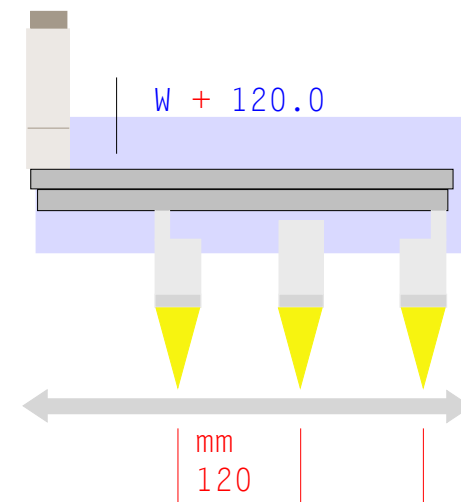
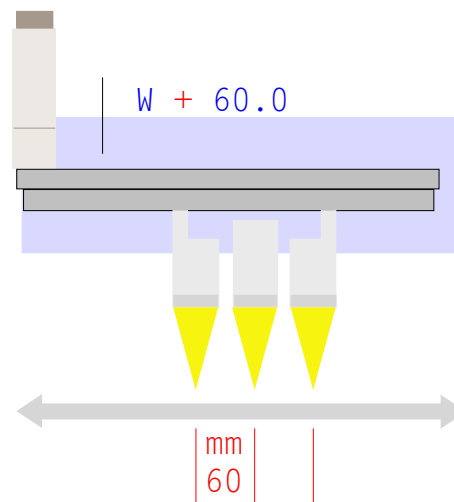
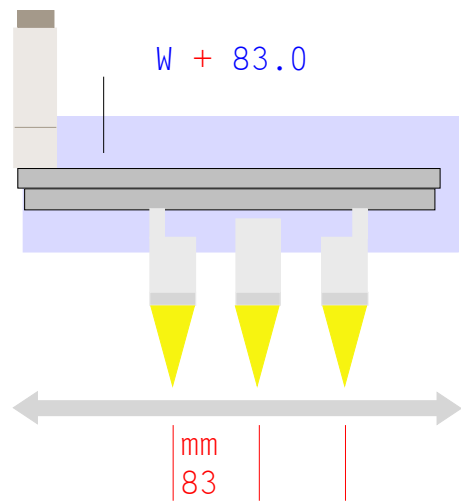
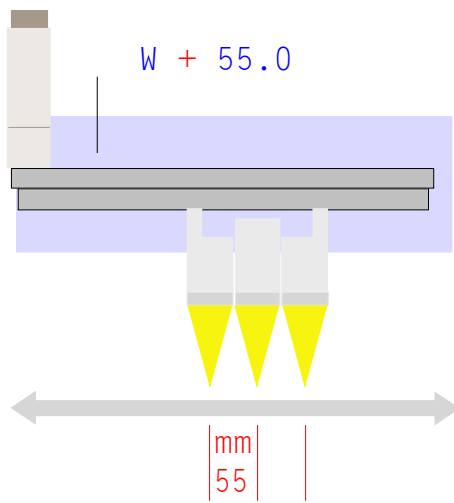

'Z' AXIS or 'U' AXIS controls sequence, for the advancement of the 'Z' axis or 'U' axis

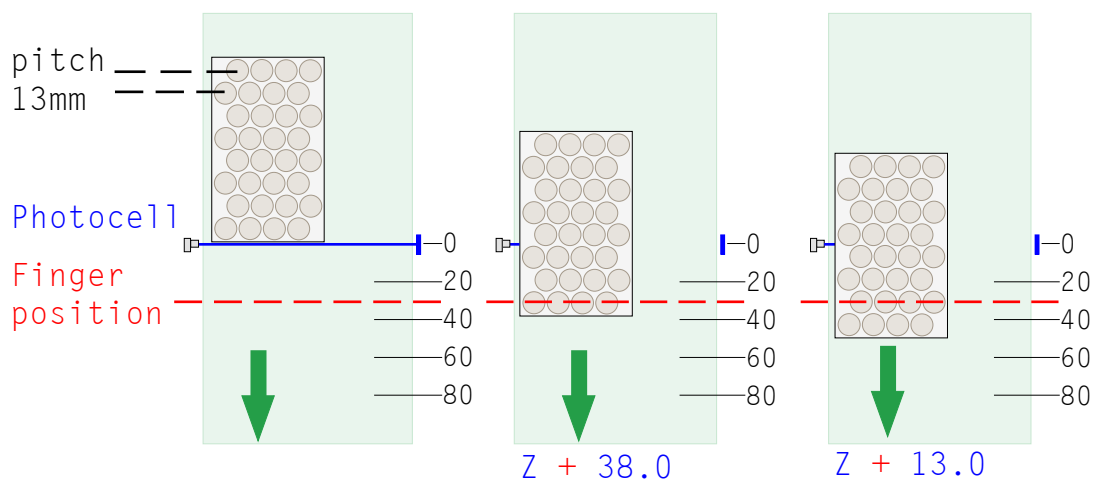

tea
 PROJECT

via Zatti 33/c
 42100 Reggio E.
 ITALIA
 tel. +39 0522
 333617
 fax +39 0522
 393768

info@teaproject.it
 www.teaproject.it

CHAPTER 14: PROGRAMMING GUIDE

ATTENTION PLEASE!! THE EXAMPLE IS BASED ON A THREE HEAD SETTING

Introduction

The XP400. Transplanter is essentially a pick-and-place robot. Details of the plug tray and pack are fed into the computer memory, thereby driving the mechanism back and forward between pickup and placing positions. Each axis of movement of the machine is designated by a letter (see Fig.1), and each axis has a datum (or zero) position. The following basic data and tray dimensions have to be fed into the computer memory:

- The finger spacing
- The pickup or planting depth
- The No fingers
- The start position
- The number of steps across the tray, and the pitch dimension across
- The number of steps in the length of the tray, and the pitch dimension in the length

Up to 60 memories (30 for plug trays and 30 for packs) are available to store data, and the data remains in memory until it is overwritten. All instructions are entered through the control panel.

Manual Movement of the Machine Axes

It is useful to be able to move the mechanisms manually when collecting information about the tray when preparing the programming sheet. After switching on, the machine goes through an important resetting routine, which resets the machine axes to their datum positions. Press the large green **Reset** button and then the **END/HOME** button on the keypad to initiate this routine. The machine will then default to the Automatic menu and the display will read as follows:

```
P: 1 PICKUP
P: 1 PLANTING
```

Change the speed setting to 5% by pressing the **↑** and **↓** keys. This will allow you to move the axes at a controllable speed when you enter the manual mode.

Press the **MENU** key and the display will show:

```
<1>AUTO <2>MAN.
<3>DATI <4>TEST
```

Press the **2** key to enter manual mode. The display will show:

The dimensions shown (represented here by nnn.n) are

the distances from the datum positions.

```
X+ nnn.n v+ n.n
Y+ nnn.n v+ n.n
```

The F1 key will toggle between the two displays

```
U+ nnn.n
Z+ nnn.n
```



The axes can be moved by pressing the buttons as follows:

Moves the X axis left to right.



Moves the Y axis up and down.



Moves the W axis (finger spacing) between the dimension which are set in the pickup and placement programs which were active when entering manual mode.

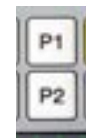

The U and Z axes can be controlled with the larger control buttons below the control keypad. Turn and hold the **Manual** switch clockwise and press the **Axis U** or **Axis Z** buttons to move these axes manually. The needles can be extended by turning the **NEEDLES EXTEND** switch.

Pressing and holding the manual movement buttons will make the pick up heads move continuously while the button is depressed. Brief/quick presses of these buttons (and the U and Z axis buttons) will make short movements.

Use the controls to move the mechanism around, taking care not to hit the fingers on the tray guides or tray restraint. Take a few minutes to familiarise yourself with the controls.

Do not enter the Machine Data menu unless instructed by TEA dealer or their appointed service agent. The Test I/O menu is used for fault finding and need not be entered unless instructed.



via Zaffi 33/c
42100 Reggio E.
ITALIA
tel. +39 0522
333617
fax +39 0522
393768

info@teaproject.it
www.teaproject.it

Fig. 1 Machine Axes

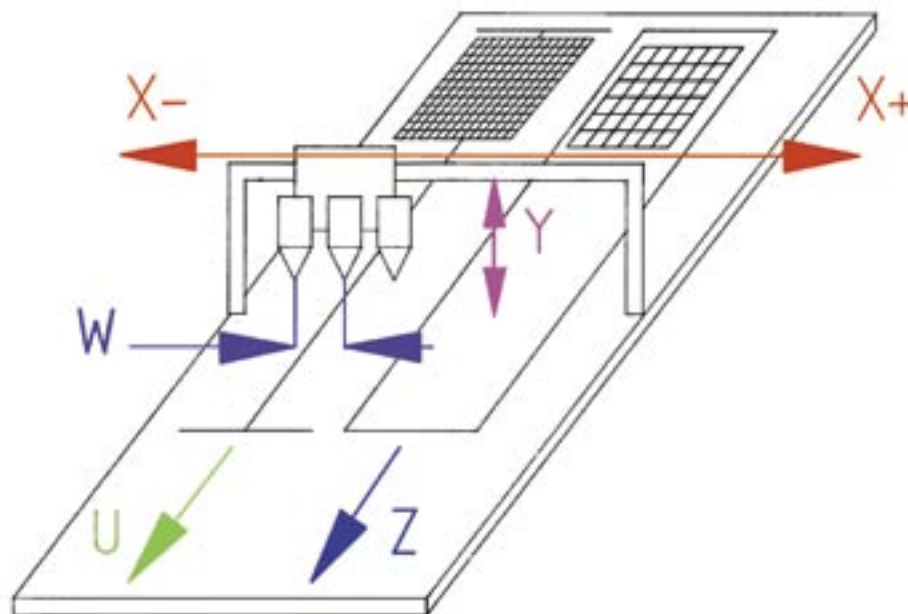

Programming a Plug Tray (Example 1) – The Objective

Example 1 (Figs. 2&3) uses a Landmark 288 plug tray. All the data can be entered into the machine and the program can then be tested with the sample tray provided. Firstly, determine from the plug tray how many pick up heads are to be used. In this example, 3 heads are required to plant into a pack 3 across. First, cells 1a, 5a and 9a are removed. Next, the heads are moved one row to the left (Axis X-) and cells 2a, 6a and 10a are removed. Next, the heads are moved one row to the left (Axis X-) and cells 3a, 7a and 11a are removed. The heads are then moved another row to the left and 4a, 8a and 12a are removed, thus emptying the first line of cells. The transplanter will then index the tray forward 1 line of cells to row b (Axis U) and move the heads back to the right (over cells 1b, 5b and 9b). The cycle will then repeat 23 times until the last line of cells in the plug tray is empty, thereby completing the program.

Things to Note when Preparing for Programming.

On a standard 3 head Transplanter the maximum finger spacing is 135mm, and the minimum spacing is 55mm. If the spacing of the plugs to be removed is greater than 135mm, a more advanced program may be necessary. In this case contact TEA dealer for advice. Accuracy when taking dimensions from the plug tray is most important. Any error will accumulate, so if you make an error of 1mm in the plug spacing and the Transplanter is asked to index 30 times, the error will be 30mm. To eliminate the error as much as possible we suggest that when measuring

the pitch of the cells in a plug tray, you measure over 10 or more cells and divide the answer by the amount of pitches being measured. This will then divide the error by that amount. Using the tray in Example 1, if the distance you measure over 12 cells is 238mm, divide that by 11 = 21.63 mm plug centres. The machine only allows the use of one decimal place, so round this to 21.6mm. Do not assume that the pitch across and in length are the same. In most cases they are not. In our example 10 pitches in the length of the tray measures 215mm, making the pitch in the U axis 21.5mm. When measuring centre to centre distances on plug trays it is more accurate to measure from edge to edge of the plug, as shown on the plug tray in Fig. 2.

Stage 1 – Preparing the Programming Sheet

The programming below relates to Example 1, the Landmark 288. (See Fig.3).

1. Enter as much information on the programming sheet as you can before entering the information into the programming panel.
2. **FINGER SPACING W AXIS.** This is the distance you want the pick up pins to space out, **86.4mm** in our example. (This is the equivalent of three pitches in this case).
3. **FINGER DEPTH <PICKUP>.** This is the depth the pick up pins go into the plug cell. The distance is taken from the datum, the carriage being in the fully up position. It is **180mm** from the datum to the transplanter table. We suggest you measure the distance between the transplanter table and the

tea
PROJECT

via Zaffi 33/c
42100 Reggio E.
ITALIA
tel. +39 0522
333617
fax +39 0522
393768

info@teaproject.it
www.teaproject.it

Figure 2

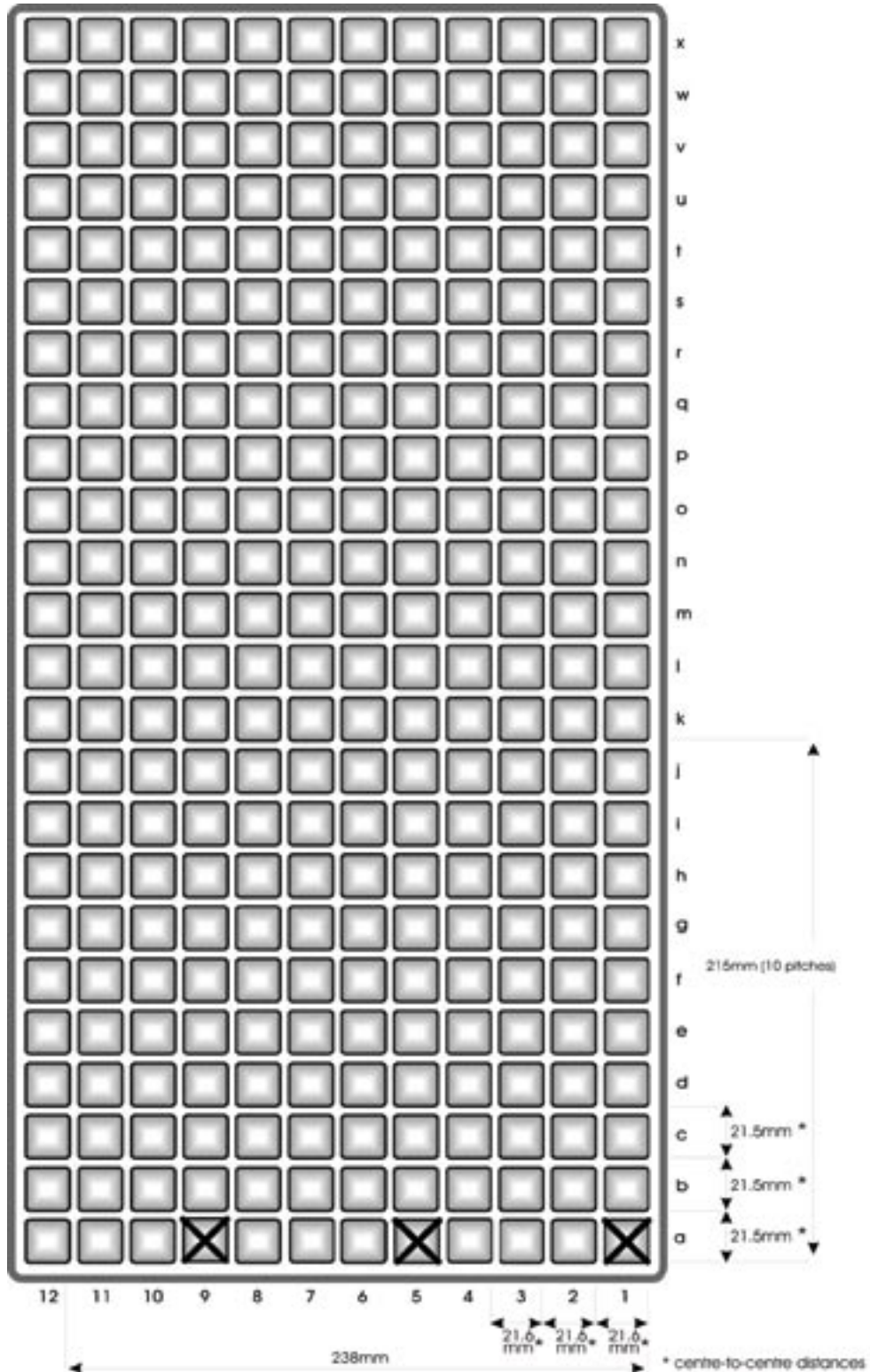

via Zatti 33/c
42100 Reggio E.
ITALIA
tel. +39 0522
333617
fax +39 0522
393768

info@teaproject.it
www.teaproject.it

position you want the tip of the pins to stop in the plug cell (approx 5mm above the bottom of the cell). Deduct this dimension from 180mm. In Example 1, Finger depth <Pickup> is to be 175mm as the plug tray is shallow and the tray base is flat on the Transplanter table. If the plug tray was of the type that has legs (making the plug base stand clear of

the Transplanter table) then this dimension would obviously be less.

4. **TRAVERSE HEIGHT AXIS Y.** This is to set the distance the machine requires the pick up head to raise up before it moves across to the placement position. The value is not adjustable.

Fig. 3

PICK-UP (PLUG TRAY)

CONTAINER

No. of holes 288

Manufacturer LANDMARK

notes

* Note that line L1 is entered after entering Manual Mode (Stage 3)

PROGRAMMING SHEET

Customer PROGRAMMING
EXAMPLE 1

date program No.
29

Head No.s used
3

FINGER SPACING
W 86.4mm

FINGER DEPTH
PICKUP 175.0mm

*TRAVERSE HEIGHT
AXIS Y 120.0mm*

* $_L\ 1^*X+ 328.2x_1$
 $_0x_0U+ _43.0x_1$

$_L\ 2^*X- _21.6x_3$
 $_0x_0U+ _0.0x_0$

$_L\ 3^*X+ _64.8x_1$
 $_2x23U+ _21.5x_1$

$_L\ 4^*X_ _ _ _ _ x_ _$
 $_ _ x_ _ U+ _ _ _ _ _ x_ _$

$_L\ 5^*X_ _ _ _ _ x_ _$
 $_ _ x_ _ U+ _ _ _ _ _ x_ _$

$_L\ 6^*X_ _ _ _ _ x_ _$
 $_ _ x_ _ U+ _ _ _ _ _ x_ _$

$_L\ 7^*X_ _ _ _ _ x_ _$
 $_ _ x_ _ U+ _ _ _ _ _ x_ _$



via Zaffi 33/c
42100 Reggio E.
ITALIA
tel. +39 0522
333617
fax +39 0522
393768

info@teaproject.it
www.teaproject.it

- Program Line L1. $L1\ X+ 00.0x0 \# 00x00\ U+ 00.0x0$ This is the start position for transplanting which places the heads over the first group of four plugs to be removed. This line can only be entered when the rest of the program has been completed and stored in the computer's memory. The X and U start dimensions are determined by entering manual mode. This process will be described later, after data entry has been made into the computer, in Stages 3 & 4.
- Program Line L2. $L2\ X- 21.6x3 \# 00x00\ U+ 00.0x0$ The X dimension is the distance you want the heads to step to the left to pickup the next group of 3 plugs to be removed, i.e. -21.6mm. The '3' denotes the amount of times you want it to do that, i.e. 3 times. Note that the X setting is negative to move the carriage to the left. Also note that X is the only axis that uses a negative number. At this point in the program the 3 heads will have emptied the first line of the plug tray. The U and r.lin

settings are left as zero as you do not require the U axis to move, nor do you require any line repeats at this part of the program

7. Program Line L3: $L3 X+ 64.8 \times 1 \quad 2 \times 23 U+ 21.5 \times 1$ The X dimension is the distance required for the heads to travel to the right to return to the start position. The X axis is to move 64.8mm to the right (back to row 1) by the amount of times you require to do this, ie $x \quad 1$ (once).

The U dimension is the distance you want to index the tray forward i.e. 1 row of cells in the length of the tray, 21.5 mm in this case, by the amount of times you want to do this, i.e. $x \quad 1$.

02×23 means "repeat line ? x ? times".

To recap this example so far, we have removed the first group of 3 plugs, stepped the heads twice to the left, moved the heads to the right to the start position, and indexed the tray forward. You now want the Transplanter to repeat the cycle the from Line L2 an additional 23 times to remove the remaining lines of plugs in the length of the plug tray (23 because the first line has already been removed). Enter $r.lin > 2 \times 23$ to set the repeat.

Stage 2 – Loading and Storing

the Program Control Buttons used when Storing a Program:



Advances the cursor along each step of the program line and then back to the beginning of the line.



Moves the cursor to the next program line.



Moves the cursor to the next program line.
Moves the cursor down to the next program line



Clears the entry above the current cursor position



"F1" Changes the entry value from + to -.



Marks the end of the program and exits programming mode. ("END/HOME")

1. Press the **MENU** button to go back to the main menu, and press **1** for Automatic Mode. Press **P1** to take the cursor under PU (Pick Up/plug tray program). Enter a program number from 1–30 that you want to allocate to the plug tray being programmed, say **29**. The display should now read **PU29**. With the cursor still under the PU29 press and hold the **MEM** button and then press the yellow \leftrightarrow button once. The display should change as you enter programming mode.
2. The display should read **FINGER SPACING AXIS W**. The dimension in our Example 1 is 86.4mm.
Enter **8 6 4** on the numeric keypad. Note that there is no decimal point key. For 60.1 you would enter 6-0-1. For 112.3 you would enter 1-1-2-3, etc. If you make a mistake press the **C** key and re-enter the correct value.
3. Press **MEM** or \downarrow to move the cursor to **FINGER DEPTH <PICKUP>** The dimension in the example is 175mm. Enter **1750**.
4. Press **MEM** to move cursor to **TRAVERSE HEIGHT AXIS Y**. this can be left at **120.0**.
5. Press **MEM** or \downarrow to move cursor to Line L1. You have no dimension to enter yet from the programming sheet. We will come back later to enter the X and U dimensions once determined.
6. Press **MEM** or \downarrow to move the cursor to Line L2. Press **F1** to change the X+ to X-. Enter the dimension, the example is X-21.6. Press the yellow \leftrightarrow button once to move the cursor to **x** and enter 3. You don't want the U axis to move, or any line repeats at this point so this can be left as zero. Line L2 should read: **L2 X-21.6x3 # 0x0 U+ 0.0x0**.
7. Press **MEM** or \downarrow to move the cursor to Line L3 and enter the X+ dimension of 64.8. Press the yellow \leftrightarrow button to move the cursor to the x (times) position

and enter 1. Press the yellow \leftrightarrow button to move the cursor to the U position and enter 21.5. Press the yellow \leftrightarrow button to move the cursor to the x (times) position and enter 1. Press the yellow \leftrightarrow button to move the cursor to the r.lin> position and enter the line number you want the cycle to repeat from, in this case Line L2. Press the yellow \leftrightarrow button to move the cursor to the x (times) position and enter 23.

Line L3 should read: L3 X+ 64.8x1 2x23
U+ 21.5x1.

8. To store the information to the computer memory make sure the cursor is under the number 23 and press and hold the END/HOME button until the display returns to the automatic menu (approx 5 seconds). This marks the end of the program after the last piece of information has been entered. The information is now stored. It is essential that the button is held until the display changes as this provides the computer with the 'end of cycle' position.
9. You now have to establish the X and U start dimensions for Line L1. Adjust the plug tray guides and tray restraint to suit the plug tray you have programmed. It is important to ensure that the formed sides of the plug tray run on the guide rollers, not any cut or trimmed edges which may be inconsistent. These edges should run under the rollers. Place the plug tray on the belt, so that one of the indexing strips is tight against the back edge of the tray. Change the operating speed with the $\uparrow \downarrow$ buttons reduce the speed to 5%. This will allow you to make slower, more precise movements when in manual mode. To obtain the X and U axis start dimensions for Line L1 of the program you have to enter manual mode.

Stage 3 – Entering Manual Mode to obtain the Start Position

Look at the beginning of this chapter for a summary of manual mode operation. Make sure you are confident with the manual movements of the machine axes before proceeding. Pressing and holding the manual movement buttons will make the pick up heads move continuously while the button is depressed. Brief/quick presses of these buttons (and the U and Z axis buttons) will make short movements. The speed of the pick up heads in the X, Y, and W axis is determined by the speed % in the main menu. Always reduce the speed % to approx. 5% before entering manual mode.

To enter manual mode press the MENU button. Press 2 to select manual, and the display should read:

```
X+ nnn.n v+ n.n
Y+ nnn.n v+ n.n
```

By pressing F1 the display should read:

```
U+ nnn.n
Z+ nnn.n
```

1. Raise the heads enough to allow the pick up pins (when extended) to clear the plug tray. Press the P1 and P2 button to move the head spacing in the W axis to that you have set for the plug tray you are programming. In the example this is 64.8mm.
2. Twist the extend pins switch to extend the pick up pins. Twist and hold the manual switch and push the U axis button to drive the plug tray towards the pick up position. Inch the U axis button to align the pick up pins with the centre of the plug cells in the U axis. Note the U dimension in the display and enter it on your programming sheet Line L1. (In our example, U+43.0x1). This is the dimension from the point the plug tray moving in the U axis hits the micro switch, zeros its reading, and starts to count and stop at the pick up position.

Check the axis W dimension in the display shows the finger spacing dimension you have programmed ie 68.4. Using the $\uparrow \downarrow$ and $\leftarrow \rightarrow$ buttons align the pick up pins in the X axis with the centre of the plug cells to be removed first (in Example 1 this is 1a, 4a, 7a & 10a). The X dimension shown in the display is the dimension of axis X from its datum/reference point to the first cells to be removed. Note this dimension on your programming sheet in Line L1. (In our example X+328.2x1). Twist the Extend Pins switch back to retract the pick up pins. These two dimensions now have to be entered into line L1 of the program.

Stage 4 – Entering the Start Position in the Program

Push the MENU button. When the display changes, press 1 to select automatic. Press P1 to display the cursor under PU29 (plug tray). Press and hold the MEM button and press the yellow \leftrightarrow button once to enter programming mode. Press MEM or \downarrow to move the cursor down to line L1. Press the \leftrightarrow button and move the cursor to the X+ position and enter the dimension 328.2. Press the \leftrightarrow button to move to the x(times) position and enter 1 time. Press the yellow \leftrightarrow button to move the cursor to the U+ position and enter the dimension 43.0. Now press the \leftrightarrow and enter the number of times you want to make this movement i.e. x1 time. Line L1 for the example tray should now read: L1 X+ 328.2x1 00x00 U+ 43.0x1 The repeat should be left as zero as there is no repeat required at this point in the program. You do not press and hold the

END/HOME button to store this information. Only do this if you extend the program, not if you change or edit the information. Press **MENU** button and the display should change. Press 1 to select automatic. Press **START** and the empty plug tray you have been using to set up will

be ejected. Load the empty plug tray back onto the transplanter and watch carefully as the transplanter carries out all your programmed instructions. If there are any errors edit program as required.

Fig. 4 Pack – Example 2

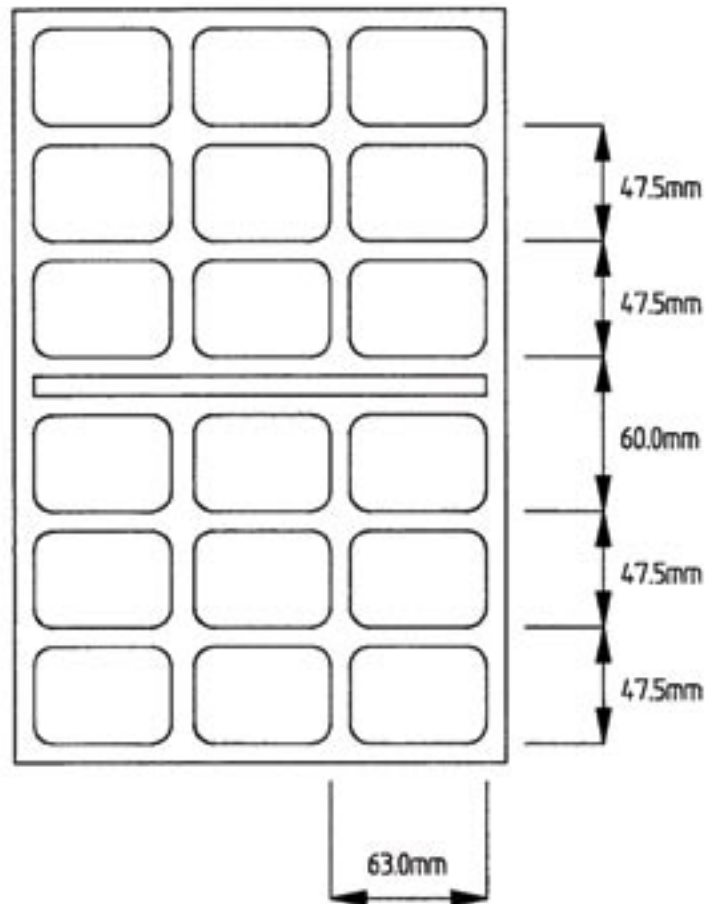

Programming a Pack (Example 2)

The Objective

Example 2 (Figs.4&5) uses a typical Euro size Double 12 cell pack. Programming is completed in a similar way to the Plug Tray, in four stages. In our example the pack is four rows across, thereby using four heads on the Transplanter. The machine will plant into the first row of the pack, and then the pack is advanced row-by-row for all six rows. Unlike the plug tray example, the X Axis always returns to the same planting position. Also, the pack is advanced in the Z axis, compared with the U Axis of the plug tray.

Things to Note when Preparing for Programming.

On a standard 3 head Transplanter the maximum finger spacing is 135mm, and the minimum spacing is 55mm. If the spacing of the plugs to be removed is greater than 135mm, a more advanced program may be necessary. In this case contact TEA dealer for advice. Accuracy when taking dimensions from the pack is most important. Any errors will accumulate, so if you make an error of 1mm in the pack spacing and the Transplanter is asked to index 6 times, the error will be 6mm. To eliminate the error as much as possible we suggest that when measuring the pitch of the cells in a pack, you measure over as many cells and divide the

Figura 5

PLACEMENT

Tray features

hole No 24 (2x12)

Manif.

material Termoformato

notes

**

Note that line L1 is entered after entering Manual Mode (Stage 3)

Customer **Programming Example 2**

date

programm No 4

finger No

3

FINGER SPACING
W 125.0mm

FINGER DEPTH
PICKUP 110.0mm

* *_L 1*X+ 688.0x_1
_0x_0Z+ _66.5x_1

_L 2*X+ __0.0x_1
__x__Z+ _47.5x_1

_L 3*X+ __0.0x_1
__x__Z+ _47.5x_1

_L 4*X+ __0.0x_1
__x__Z+ _60.0x_1

_L 5*X+ __0.0x_1
__x__Z+ _47.5x_1

_L 6*X+ __0.0x_1
__x__Z+ _47.5x_1

answer by the amount of pitches being measured. This will then divide the error by that amount. Using the tray in Example 2, you can only really measure over 2 cells (95mm), and dividing that by 2 gives 47.5 mm centres. The gap in the middle of the tray is different (60mm). The pitch across the tray used in our example is 63mm, and this will be the finger spacing. More complicated programs can be written for other tray formats (zig-zag patterns, two plugs per cell, etc.). Contact TEA dealer for advice.

Stage 1 - Preparing the Programming Sheet

The programming below relates to Example 2, the 2 x 12 pack. (See Fig.5).

1. Enter as much information on the programming sheet as you can before entering the information into the programming panel.
2. Axis W, finger spacing. This is the distance you want the pick up pins to space out, 63.0mm in our example.
3. Finger Depth <Planting>. This is the depth the pick up pins go into the pack cell. The distance is taken from the datum, the carriage being in the fully up position. It is 180mm from the datum to the transplanter conveyor belt. We suggest you measure the distance between the belt and the position you want the tip of the pins to stop in the cell. Deduct this dimension from 180mm. In Example 2, Finger Depth <Planting> is to be 145mm. This depth can be adjusted while the machine is running.
4. Program Line L1.
`L1 X+__0.0x0 00X00 Z+ 00.0x 0` This is the start position for transplanting which places the heads over the first line of cells in the pack. This line can only be entered when the rest of the program has been completed and stored in the computer's memory. The X and Z start dimensions are determined by entering manual mode. This process will be described later, after data entry has been made into the computer, in Stages 3 & 4.
5. Program Line L2.
`L2 X+__0.0x1 00X00 Z+ 47.5x1` The X dimension is the distance you want the heads to move in the X Axis relative to the position they stopped in program line L1. In this case no movement from that position is required, and so a dimension of zero is entered. The x1 has to be entered, even though the X dimension is zero. The x1 is entered because you require the heads to move to the same planting position x1 time. The Z+ 47.5 is the distance you want to step the pack forward to the second line of cells in the pack.
6. Program Line L3.
`L3 X+__0.0x1 00X00 Z+ 47.5x 1` As in line

L2, this moves the pack to the third row.

7. Program Line L4
`L4 X+ __0.0x1 00X00 Z+ 60.0x 1` This line advances the pack 60mm to take into account the larger spacing at the centre of the tray.
8. Program Line L5.
`L5 X+ __0.0x1 00X00 Z+ 47.5x 1` This moves the pack to the fifth row.
9. Program Line L6.
`L6 X+ __0.0x1 00X00 Z+ 47.5x 1` This moves the pack to the sixth and last row.

Stage 2 - Loading and Storing the Program

Control Buttons used when Storing a Program:



Advances the cursor along each step of the program line and then back to the beginning of the line.



Moves the cursor to the next program line.



Moves the cursor up to the previous program line.

Moves the cursor down to the next program line.



Clears the entry above the current cursor position.



Changes the entry value from + to -.



Marks the end of the program and exits programming mode

tea
PROJECT

via Zaffi 33/c
42100 Reggio E.
ITALIA
tel. +39 0522
333617
fax +39 0522
393768

info@teaproject.it
www.teaproject.it

1. Press the **MENU** button to go back to the main menu, and press 1 for Automatic Mode. Press **P1** to take the cursor under PU (Pick Up/plug tray program). Press the yellow \leftrightarrow button to position the cursor under PL (Placing/Pack program). Enter a program number from 1–30 that you want to allocate to the pack being programmed, say 29. The display should now read PL29. With the cursor still under the PL29 press and hold the **MEM** button and then press the yellow \leftrightarrow button once. The display should change as you enter programming mode.
2. The display should read **FINGER SPACING AXIS W**. The dimension in our Example 1 is 63.0mm.
3. Enter **6 3 0** on the numeric keypad. Note that there is no decimal point key. For 60.1 you would enter 6-0-1. For 112.3 you would enter 1-1-2-3, etc. If you make a mistake press the **C** key and re-enter the correct value.
4. Press **MEM** or \downarrow to move the cursor to **FINGER DEPTH <PLANTING>**. The dimension in the example is 145mm. Enter 1450.
5. Press **MEM** or \downarrow to move cursor to Line L1. You have no dimension to enter yet from the programming sheet. We will come back later to enter the X and Z dimensions once determined.
6. Press **MEM** or \downarrow to move the cursor to Line L2. Press the yellow \leftrightarrow button once to move the cursor to **x_** and enter 1. Press the yellow \leftrightarrow button again and enter the Z dimension of 47.5. Press the yellow \leftrightarrow button yet again to move the cursor to **x_** and enter 1.
Line L2 should read **L2 X+ 0.0x1 Z+ 47.5x1 r.lin> 0x0**
7. Repeat step 5 above for lines L3 to L6, noting that the Z dimension in line L4 is 60mm.
8. Line L6 should read: **L6 X+ 0.0x1 Z+ 47.5x1 r.lin> 0x0**. To store the information to the computer memory make sure the cursor is under the second zero of the **r.lin> 0x0**, and press and hold the **END/HOME** button until the display returns to the automatic menu (approx 5 seconds). This marks the end of the program after the last piece of information has been entered. The information is now stored. It is essential that the button is held until the display changes as this provides the computer with the 'end of cycle' position.
9. You now have to establish the X and Z start dimensions for Line L1. Adjust the tray guides to suit the pack you have programmed. Place a pack on the conveyor belt. Change the operating speed with the $\uparrow\downarrow$ buttons reduce the speed to 5%. This will allow you to make slower, more precise movements when in manual mode. To obtain the X and Z axis start dimensions for Line L1 of the program you have to enter manual mode.

Stage 3 - Entering Manual Mode to obtain the Start Position

Look at the beginning of this chapter for a summary of manual mode operation. Make sure you are confident with the manual movements of the machine axes before proceeding. Pressing and holding the manual movement buttons will make the pick up heads move continuously while the button is depressed. Brief/quick presses of these buttons (and the U and Z axis buttons) will make short movements. The speed of the pick up heads in the X, Y, and W axis is determined by the speed % in the main menu. Always reduce the speed % to approx. 5% before entering manual mode.

To enter manual mode press the **MENU** button. Press 2 to select manual, and the display should read:

```
X+ nnn.n v+ n.n
Y+ nnn.n v+ n.n
```

By pressing **F1** the display should read:

```
U+ nnn.n
Z+ nnn.n
```

1. Raise the heads enough to allow the pick up pins (when extended) to clear the pack. Press the **P1** and **P2** button to move the head spacing in the W axis to that you have set for the pack you are programming. In the example this is 63.0mm.
2. Twist the extend pins switch to extend the pick up pins. Twist and hold the manual switch and push the Z axis button to drive the pack towards the planting position. Inch the Z axis button to align the pick up pins with the centre of the pack cells in the Z axis. Note the Z dimension in the display and enter it on your programming sheet Line L1. (In our example, Z+ 66.5x1). This is the dimension from the point the pack (moving in the Z axis) breaks the beam, zeros its reading, and starts to count and stop at the planting position. Check the axis W dimension in the display shows the finger spacing dimension you have programmed ie 63.0. Using the $\uparrow\downarrow$ and $\leftarrow\rightarrow$ buttons align the pick up pins in the X axis with the centre of the first row of the pack. The X dimension shown in the display is the dimension of axis X from its datum/reference point to the first cells to be planted. Note this dimension on your programming sheet in Line L1. (In our example X+ 688.0x1). Twist the Extend Pins switch back to retract the pick up pins. These two dimensions now have to be entered into line L1 of the program.

Stage 4 - Entering the Start Position in the Program

Push the **MENU** button. When the display changes, press 1 to select automatic. Press **P1** to display the cursor under PU (plug tray). Press the yellow \leftrightarrow button to position the cursor under PL29 (Placing/Pack program). Press and hold the **MEM** button and press the yellow \leftrightarrow button once to enter programming mode. Press **MEM** or \downarrow to move the cursor down to line L1. Press the \leftrightarrow button and move the cursor to the X+ position and enter the dimension 688.0. Press the \leftrightarrow button to move to the x(times) position and enter 1 time. Press the yellow \leftrightarrow button to move the cursor to the Z+ position and enter the dimension 66.5. Now press the \leftrightarrow and enter the number of times you want to make this movement i.e. x1 time. Line L1 for the example tray should now read:

L1 X+ 688.0x1 Z+ 66.5x1 r.lin>0x 0 . You do not press and hold the **END/HOME** button to store this information. Only do this if you extend the program, not if you change or edit the information. Press **MENU** button and the display should change. Press 1 to select automatic. Press **START** and the empty pack you have been using to set up will be ejected. Load an empty plug tray and pack onto the transplanter and watch carefully as the transplanter carries out all your programmed instructions. If there are any errors edit program as required.

Note:

In Example 2, we have written one program line for each line in the pack. This is to illustrate how to handle the uneven spacing in the length of the tray. However, it is possible to make the program a little shorter by setting the repeat in line L4 as r.lin>2x1, and not using lines L5 and L6.



via Zatti 33/c
42100 Reggio E.
ITALIA
tel. +39 0522
333617
fax+39 0522
393768

info@teaproject.it
www.teaproject.it

CHAPTER 15: MAINTENANCE

Introduction

Careful cleaning of the machine's moving parts is fundamental for it to function correctly.
Avoid build-ups of soil and dirt.
Avoid cleaning the machine with water.
Before servicing or any other mechanical operation disconnect both the electricity and air supply.

15.1 Daily servicing

Always remove dust and soil with compressed air after use.

Clean the tracks of the X and Y Axis trolley with a soft dry cloth.

Apply a thin film of air-line oil to the roller tracks.

Check that the fingers of the transplanting heads are free from soil or other materials; dip the finger in water and turn the "NEEDLES EXTEND" switch repeatedly.

Check the air filter; empty it by pushing the button under the bowl.



15.2 Monthly servicing

During periods of heavy use we suggest that you service the machine as follows:

Check the condition of the axes' belts; check for wear and tightness. Normally the belts should last for years. Considerable wear can be caused damaged pulleys. In this case contact your authorised TEA dealer.

Check the wear of the transplanting fingers. This is usually accelerated when sandy soil is used. Replace the needles by loosening the nuts on the top and sliding them through the fingers plate. Always use needles of the same length. Usually different types of fingers are equipped with needles of different length.

Check the wear of the needle-holder tips.

Check the tightness of the conveyor belts. If loose contact



tea
PROJECT

via Zaffi 33/c
42100 Reggio E.
ITALIA
tel. +39 0522
333617
fax +39 0522
393768

info@teaproject.it
www.teaproject.it

your authorised TEA dealer.

After disconnecting the electricity check the smoothness of the X,Y and W Axis by moving them manually.

15.3 Special servicing (Extraordinary)

A special service has to be made at the end of each complete working season.



We suggest you check the machine as soon as the season is finished. For more details on servicing contact your authorised TEA dealer.

Motor brushes shorter than 5mm could be the cause of poor performance of the motors; replace them with new brushes.

Clean the brass needle-holders from dirt and soil after removing the needles.

Check the slideway wheels and tracks of the machine. If they are damaged, or not properly adjusted, it will considerably reduce the machine's life.

During periods the machine is not used, cover it with a tarpaulin, and disconnect both electricity and air supplies. The machine must be placed in a safe and sheltered place not too wet and not subjected to high changes of temperature.

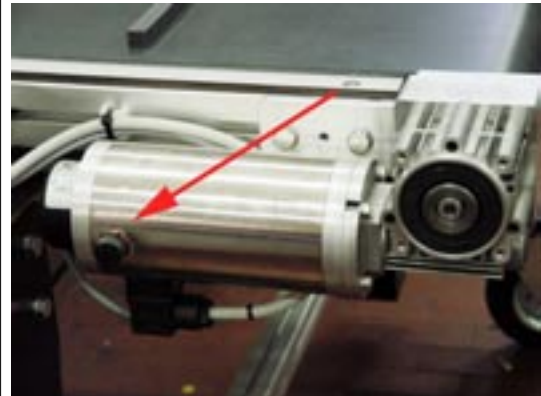

tea
PROJECT

via Zatti 33/c
42100 Reggio E.
ITALIA
tel. +39 0522
333617
fax +39 0522
393768

info@teaproject.it
www.teaproject.it

CHAPTER 16: XP 400 N

One new feature of the XP 400 line is a conveyor belt 600mm wide to transport the pickup trays in the "U" axis.

The conveyor belt which forms the Z Axis is normally 400 mm wide, the conveyor belt which forms the "Z" Axis is positioned on the right-hand side of the machine and in some models can be removed and substituted with

another conveyor system. The "Z Axis" micro switch in some models can be replaced with one or more photo-cell.

Check periodically that the photocells are clean and free from dirt and soil. The reflector should be cleaned regularly.



CHAPTER 17: ECO- FRIENDLY DISPOSAL OF OBSOLETE PARTS

ENVIRONMENTAL CONCERN SHOULD BE PARAMOUNT WHEN DISPOSING OF WORN OUT AND OBSOLETE MACHINES AND COMPONENTS.

Machines should be dismantled and each component disposed of in the most ecologically friendly manner. There are EC guidelines for the disposal of special wastes, these are available from Local Government Authorities, and should be strictly adhered to.

tea
PROJECT

via Zaffi 33/c
42100 Reggio E.
ITALIA
tel. +39 0522
333617
fax +39 0522
393768

info@teaproject.it
www.teaproject.it

Green Lane
Littlewick
Green Berks
SL6 3RH
England
Tel: +44 (0)
1628 826747
Fax: +44 (0)
1628 822284

NOTE



via Zatti 33/c
42100 Reggio E.
ITALIA
tel. +39 0522
333617
fax+39 0522
393768

info@teaproject.it
www.teaproject.it

DECLARATION OF EC CONFORMITY

(according to ISO/IEC Guide 22 and EN 45014)

N° TEADCO10599XP98

tea Project S.r.l.
via Zatti, 33/c 42100 Reggio Emilia ITALIA
DICHIARA
Ripicchettatrice

The product herewith complies with the requirements of the:

D.E. 98/37/CE (MSD)

D.E. 89/336/CEE (EMC)
mod. D.E. 93/68/CEE

D.E. 73/23/CEE (LVD)
mod. D.E. 93/68/CEE

The product described above is in conformity with the following EMC Specifications based on sample testing:
Document N° Title Edition/Date of issue

EN50081-1 Compatibilità elettromagnetica. Norma generica sull'emissione Parte 1: ambienti residenziali, commerciali e dell'industria leggera.
ottobre 1992

EN50081-2 Compatibilità elettromagnetica. Norma generica sull'immunità Parte 1: ambienti residenziali, commerciali e dell'industria leggera.
maggio 1998

ENV50204 Campo elettromagnetico irradiato da radiotelefoni numerici. Prova d'immunità.
aprile 1996

EN61000-4-2 Compatibilità elettromagnetica (EMC) parte 4: tecniche di prova e di misura. Sezione 2: prove di immunità a scarica elettrostatica. Pubblicazione Base EMC
settembre 1996

EN61000-4-3 Compatibilità elettromagnetica (EMC) parte 4: test e tecniche di misura. Sezione 3: test di immunità ai campi magnetici irradiati a radiofrequenza.
settembre 1996

EN61000-4-4 Compatibilità elettromagnetica (EMC) parte 4: tecniche di prova e di misura. Sezione 4: test d'immunità ai transitori elettrici veloci (Burst). Pubblicazione di base EMC.
settembre 1996

EN61000-4-5 Compatibilità elettromagnetica (EMC) parte 4: tecniche di prova e di misura. Sezione 5: prova d'immunità ad impulso.
settembre 1995

EN61000-4-6 Compatibilità elettromagnetica (EMC) parte 4: test e tecniche di misura. Sezione 6: Test di immunità ai campi elettromagnetici condotti a radiofrequenza.
luglio 1996

EN 60204-1 Sicurezza della macchina - equipaggiamento elettrico della macchina parte 1: regole generali
1997

Reggio Emilia 15/05/1999



Legale Rappresentante Sig. Bonacini Marco

tea
PROJECT

via Zatti 33/c
42100 Reggio E.
ITALIA
tel. +39 0522
333617
fax +39 0522
393768

info@teaproject.it
www.teaproject.it

HAMILTON

Green Lane
Littlewick
Green Berks
SL6 3RH
England
Tel: +44 (0)
1628 826747
Fax: +44 (0)
1628 822284

tea
PROJECT

via Zatti 33/c
42100 Reggio E.
ITALIA
tel. +39 0522
333617
fax+39 0522
393768

info@teaproject.it
www.teaproject.it